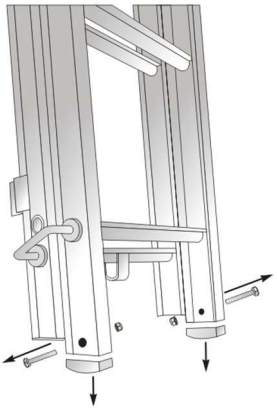
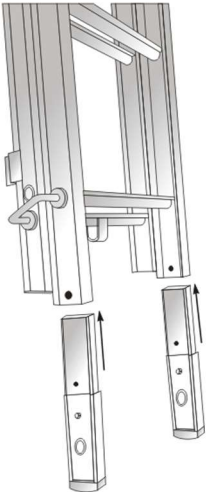
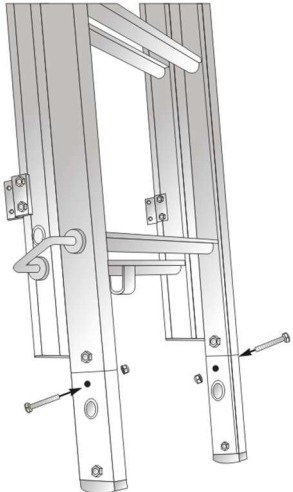
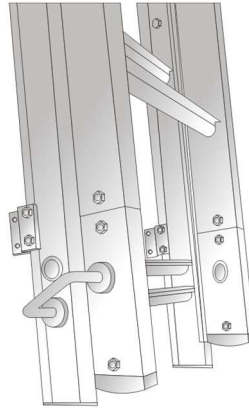

EXTENSOR DE MONTANTES PARA ESCADA DE SÓTÃO 2 LANCES (SO 226 – RS201)

ATENÇÃO: Só precisa ser instalado caso o desnível entre os pisos for superior a 3,10m com no máximo 3,20m.

Execute esta etapa após a escada já estar completamente instalada.

<p style="text-align: center;">1</p>  <p>The diagram shows a side view of the ladder's legs. Two screws are being removed from the feet, with arrows indicating their removal. The feet are shown being lifted away from the main frame.</p>	<p style="text-align: center;">2</p>  <p>The diagram shows the two extension brackets being attached to the bottom of the ladder's main frame. Arrows indicate the direction of assembly.</p>	<p style="text-align: center;">3</p>  <p>The diagram shows the screws and nuts being reinstalled into the ladder's frame. Arrows point to the specific locations where the hardware is being reattached.</p>	<p style="text-align: center;">4</p>  <p>The diagram shows the final step where the extension brackets are locked into place. Arrows point to the locking mechanism on the brackets.</p>
<p>1 - Retirar os parafusos e as porcas para poder soltar os pés que já se encontram na escada.</p>	<p>2 - Colocar os dois extensores até o final.</p>	<p>3 - Recolocar e reapertar os parafusos que foram retirados na etapa 1.</p>	<p>4 – Para guardar a escada, posicione as travas nos furos dos extensores.</p>